

eloma



Multimax





Eloma – always offering the best possible quality

Ever since it developed its first combi steamer over 30 years ago, and even with the latest generation of Multimax, Eloma has always focussed on balancing the traditional and modern. We still abide by this philosophy today to ensure that you continue to enjoy cooking.

“You have to be able to understand your customers’ business to be able to provide optimal solutions!”

We understand tradition as being **“100 percent Made in Germany”**. German engineering precision and craftsmanship guarantee the highest levels of quality!

But we go even further to ensure your satisfaction. For example, by continuing to provide you with an additional tray, larger chamber space and the tried and trusted fan wheel auto-reverse technology. **Our guarantee for superbly even cooking and the best possible product quality!**

Eloma offers this quality the world over! As a member of the international AGA Foodservice Group, the market leader in providing leading edge catering equipment to the foodservice industry, we can offer direct, quick and comprehensive support – no matter where you cook with our products!



Eloma Multimax – for especially discerning people in kitchens the world over!



Eco-logical facts about Eloma

I Inventor of the live steam system:



Live steam is generated in the chamber itself, with perfect steam saturation – ideal for sensitive delicate products, such as broccoli, dumplings, vegetables or fish.

Your benefits:

- immediate use, no need to pre-heat
- significantly reduced energy costs – up to 46%
- significantly reduced maintenance costs, compared to boiler version, no de-scaling required

I autoclean:



autoclean

Our unique, fully automatic self-cleaning system:

Your benefits:

- minimal costs thanks to the precise dosage of liquid cleaner
- start any time, no need to manually cool down or open the door
- perfect cleaning result thanks to rotating nozzle
- health protection – no contact with the cleaning agent
- no need to decant or fiddle around with cartridges or tabs

Best possible hygiene and operating safety!

I Multi-eco system:



Our multi-eco system helps you to save other resources.

Your benefits:

- high-performance heat exchanger with condensation saving as much as 42% water and 16% energy

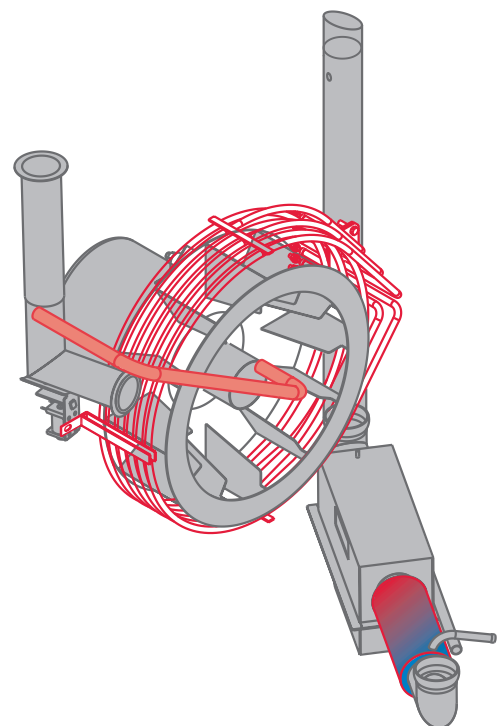

We are currently the only manufacturer of combination steamers whose multi-eco system has won the Dr.-Georg-Triebe Innovation Prize in the ecology and energy efficiency categories!



The new Eloma Multimax B: The professional all-rounder!

Functions:

- **Clima-Aktiv®**
active humidification and de-humidification of the cooking chamber
- **autoclean**
fully automatic cleaning system
- **programme memory**
99 storable programmes
- **core temperature control**
with multi-point core temperature sensor
- **Active Temp**
pre-heating or cooling
- **multi-function key**
- **auto-reversible fan wheel**
with reduced or interval speed for gentle cooking
- **manual humidification**
- **E/2 Energy saving function**

An appliance that leaves nothing to be desired!

Classic operating controls combined with high-quality finish and superb cooking performance we believe the Multimax to be **"Best in class"**!



Multimax B 6-11

Multimax B 10-11

Multimax B 20-11



8 modes of operation:

- convection (hot air)
- combi steaming
- steaming
- forced steaming
- vario steaming
- LT cooking
- ΔT cooking
- regeneration / banquet

Gas:



- high-performance pre-burner system
- low pollution burner – **kiwa**
- high-performance triple pipe heat exchanger
- optimal efficiency





The well established Eloma Multimax A: A simply wider choice!

Functions:

- convection (hot air)
- combi steaming
- steaming
- forced steaming
- vario steaming
- regeneration at 3 climate control levels
 Dry – for quick-frying and breaded food
 Medium – for vegetables, roasts and casseroles
 Moist – for rice, pasta and fish
- multi-point core temperature sensor
- reduced fan speed
- manual humidification
- cleaning programme
 The Multimax A guides you easily and reliably through the cleaning cycle.

Modern food preparation demands both high cost efficiency and high levels of flexibility.

Even the Eloma basic model Multimax A and its advanced fittings offer you a wide range of possible applications – as individual as your choice of dishes.



Multimax A 6-11

Multimax A 10-11

Multimax A 20-11



An individualised system solution offering maximum flexibility!

Combi mix:

Compact cooking station, a combination of two Eloma combi steamers: 2 x 6-11 or 6-11 + 10-11.

Flexibility, even in cramped spaces! User-friendly and practical, all modes of operation and temperature ranges can be handled simultaneously. **Optimal utilisation of existing capacities and performance guaranteed, on less than 1 m²!**



Combi mix
Multimax 6-11/6-11 and 6-11/10-11

Multi-eco hood KH 2/KH 3:



The condensation hood offering **more than 80% efficiency.**

Your benefits:

- **no water – minimum energy – maximum efficiency**



Optimal solution eliminating the need for large investments in ventilation systems – available in two sizes: KH 2 for models 6-11 and 10-11, KH 3 for model 20-11.

Left-hinged doors:

Ergonomics at their best! Door hinge and operating elements can be optionally placed to the right or the left. An option unique to Eloma!

Multi-eco hood KH 2 on
Multimax B 6-11 (left-hinged door)



Raising your appliances to perfection!

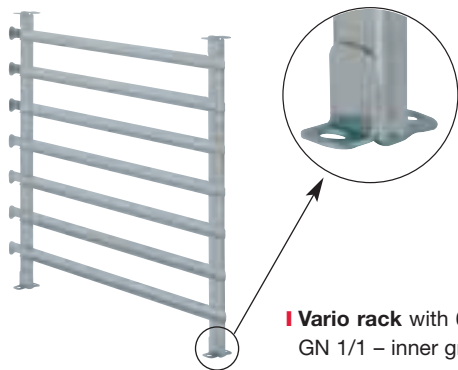

! Vario rack with 6+1 or 10+1 trays, outer grid GN 1/1 – inner grid 400 x 600 mm

Practical and perfectly matching accessories turn individual appliances into a system solution!



! Hygienic support stand for GN grids and trays, enclosed on 3 sides



! Banquet system with thermal insulation hood for up to 120 plates



! WU 14 warming cabinet with active humidification with 14 trays, GN 1/1



ProConnect: Making data management child's play!

ProConnect – an intelligent innovation for the Multimax B:

Intuitive operation

The self-explanatory user interface combines the well-known combi steamer operation with useful Windows functions.

Organising cooking programmes

ProConnect allows you to write your cooking programmes easily and quickly on a PC and to manage them in clearly organised files – in line with your individual preferences.

HACCP documentation

Simple and comprehensive documentation of all cooking processes and work data on your PC – accessible at anytime.

Data transfer made easy

At the click of a button: just send your centrally stored cooking programmes from your PC to your Eloma combi steamer and vice versa – ideal when you are working with several appliances.

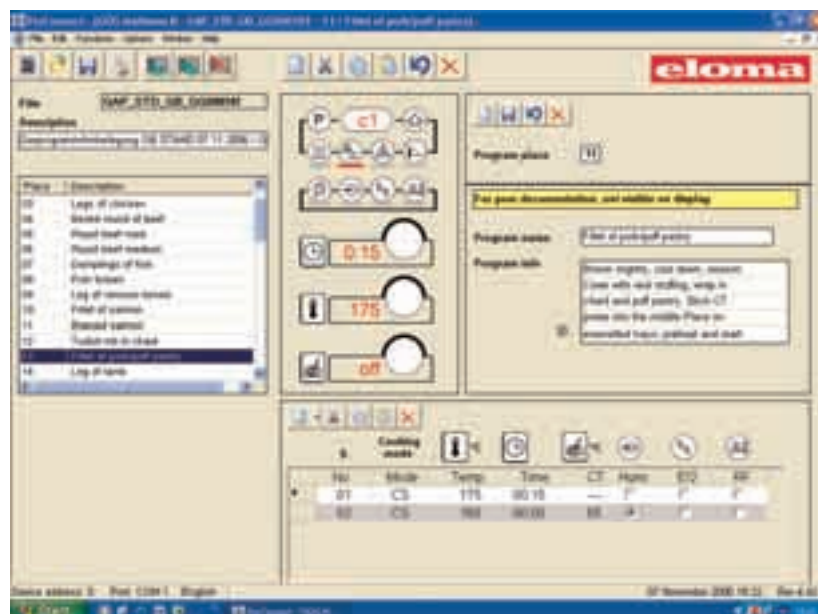



Features (summary)

- ✓ Original Eloma live steam system
- ✓ Pre-heating and rapid cooling (Active Temp) with utilisation of residual heat*
- ✓ Manual humidification
- ✓ Temperature range 30-300°C
- ✓ Integrated fat filter
- ✓ Integrated steam discharge
- ✓ Fan wheel - Auto-reverse and large cooking chamber (as much as 26% larger than our competitors) for superbly even results
- ✓ Active humidification and de-humidification with unique ventilation system*
- ✓ Clima-Aktiv®
- ✓ E/2 Energy saving function*
- ✓ Multi-point core temperature sensor
- ✓ 1 additional tray
- ✓ Hand shower
- ✓ autoclean (option)*
- ✓ Hot Spot (option)

* Multimax B only

Technical specifications (for all electrical and gas appliances)

	Multimax B – Multimax B Gas – Multimax A				
Model sizes	6-11	10-11	20-11	12-21*	20-21*
Capacity	6 x 1/1 GN	10 x 1/1 GN	20 x 1/1 GN	12 x 2/1 GN 24 x 1/1 GN	20 x 2/1 GN 40 x 1/1 GN
Trays					
Number	6 + 1	10 + 1	20 + 1	12 + 1	20 + 1
Spacing (mm)	67	67	67	67	67
Dimensions					
Width (mm)	925	925	1030	1310	1310
Depth (mm)	805	805	880	1086	1086
Height (mm)	840	1120	1930	1490	1925
Weight (kg)	130/140**	167/177**	295/320**	350/365**	495/530**
Connections					
Water inlet	2 x G 3/4 A	2 x G 3/4 A	2 x G 3/4 A	2 x G 3/4 A	2 x G 3/4 A
Water outlet Ø mm (DN)	50	50	50	50	50
Electric models					
Voltage	400 V 3N AC	400 V 3N AC	400 V 3N AC	400 V 3N AC	400 V 3N AC
Electrical Loading: kW	11	17	45	34	68
Protection: A	3 x 16	3 x 25	3 x 80	3 x 50	3 x 100
Electric models with reduced heat output					
Voltage			400 V 3N AC	400 V 3N AC	400 V 3N AC
Electrical Rating or Loading*: kW			34	26	52
Protection: A			3 x 50	3 x 50	3 x 80
Gas appliances					
Voltage	230 V N AC	230 V N AC	230 V N AC	230 V N AC	230 V N AC
Electrical Rating or Loading: kW	1	1	1,8	1,3	2,2
Protection: A	1 x 16	1 x 16	1 x 16	1 x 16	1 x 16
Gas Rating: kW	12	20	40	35	70

Casing made of nickel chromium steel CrNi 18 10.

* Multimax A is not available in sizes 12-21 and 20-21

** Weight gas units

We reserve the right to changes

The Eloma team is here to help you, around the clock!

- Experienced chefs, butchers and bakers are available to support you
- Global network of service partners
- Spare parts stock for global express despatch
- Service vehicles stocked with spare parts for quick service response

quick – reliable – personal!

